



# HMR – Linear Drive Driving the future.

ORIGA – simply the first

aerospace  
climate control  
**electromechanical**  
filtration  
fluid & gas handling  
hydraulics  
pneumatics  
process control  
sealing & shielding



ENGINEERING YOUR SUCCESS.

# EL Sizing

The dimensioning program for electric linear drives

Available on CD-Rom or as a download

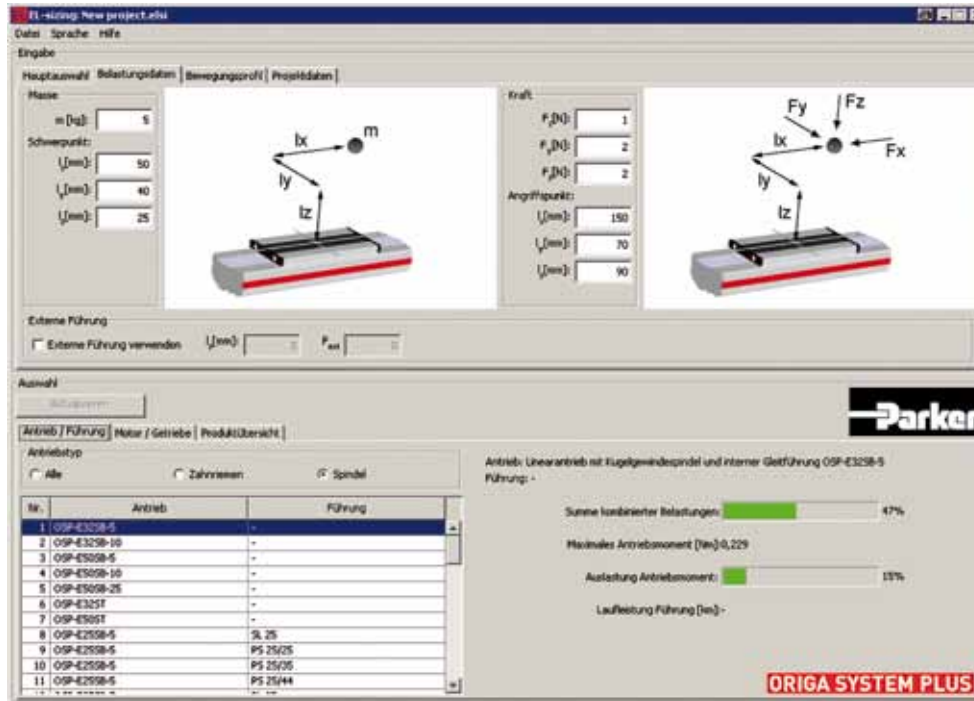

Coming soon for HMR – ORIGA DRIVE SYSTEM

# ORIGA Linear Drives

*HMR series*

*Table of Contents*

	Page
<b>Profile version</b>	<b>6</b>
- Loads, forces and bending moments	7
<b>Ball screw</b>	<b>9</b>
- Drive data	10
- Performance / thrust force	11
- Dimensions	12
- Weight, mass and inertia	13
- Order stroke	14
- Order code	16
<b>Belt</b>	<b>19</b>
- Drive data	20
- Dimensions	22
- Weight, mass, inertia	23
- Order stroke	24
- Order Code	26
<b>Options</b>	<b>29</b>
- Protection class	30
- Impact protection	31
- Position detection	32
<b>Accessories</b>	<b>35</b>
- Coupling housing	36
- Motor coupling	37
- Mountings	38
- T-slot fixture	39

# ORIGA HMR Electromechanical Linear Actuators



## Profile designs

- Basic profile for assembling directly to the machine base
- Reinforced profile for self-supporting assembly



## Mounting systems

- Integrated T-slots for attaching from below and from the side



## Protection classes

- Without cover: IP20
- With cover: IP54



## Guide systems

- Plain bearing guide
- Recirculating ball bearing guide



## Lubrication

- Central lubrication via externally accessible lubricating nipples

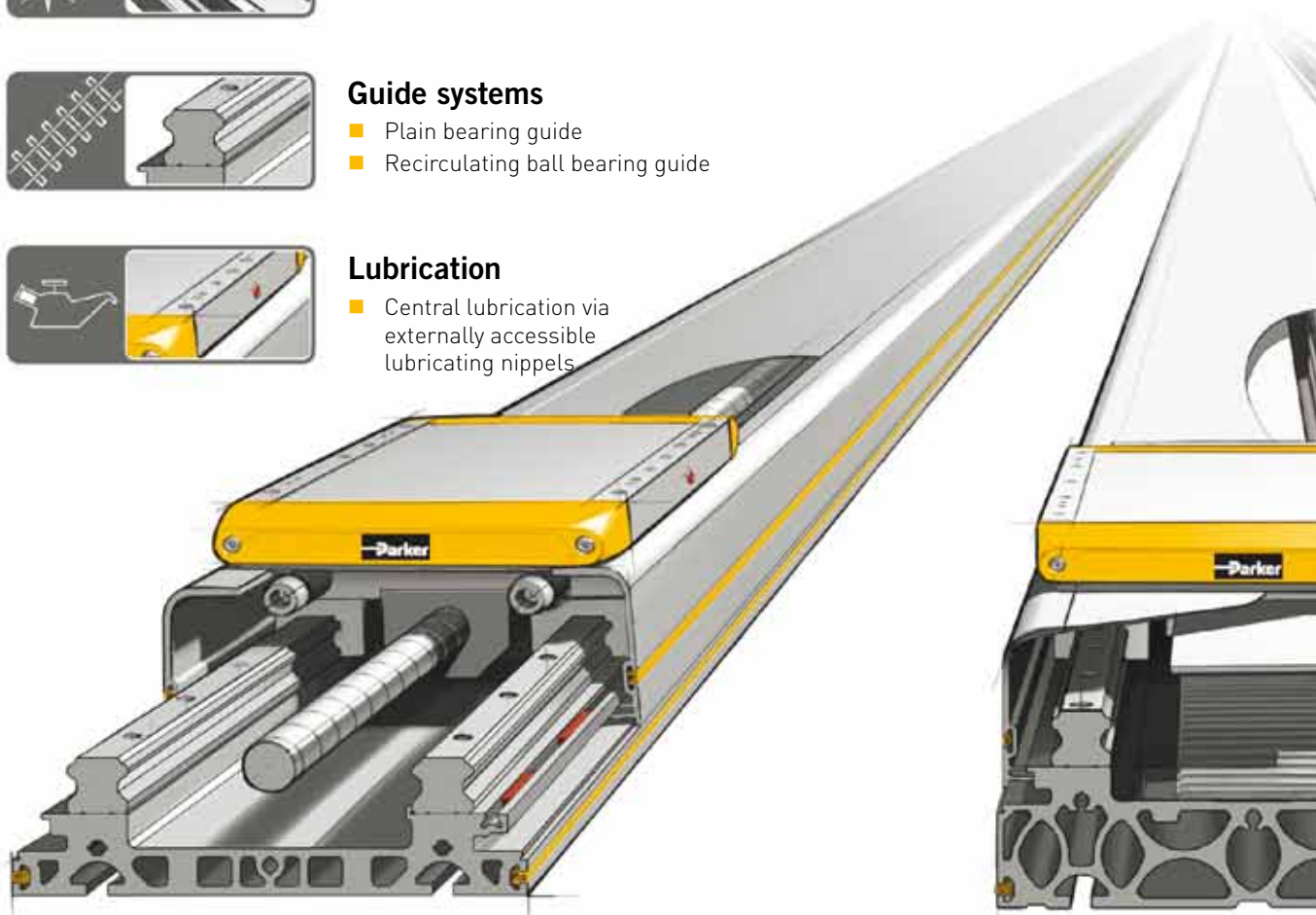

## Screw drive

The solution for precise path and position control for heavy loads



## Toothed belt drive

The solution for fast path and position control for medium load

We drive the future - with screw, toothed belt or linear motor.

### Position sensing

- Integrated, adjustable position switch for end positions and homing



### Impact protection

- Integrated shock absorbers for both end positions



### Distance measurement

- Contact-free, incremental displacement measuring system



### Brake system

- Holding brake can be implemented for horizontal and vertical movements



### Cable drag chains

- Directly attachable drag chains for various cabling

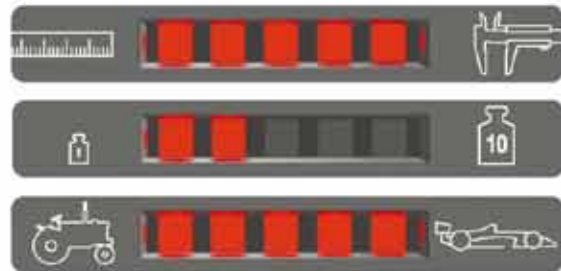
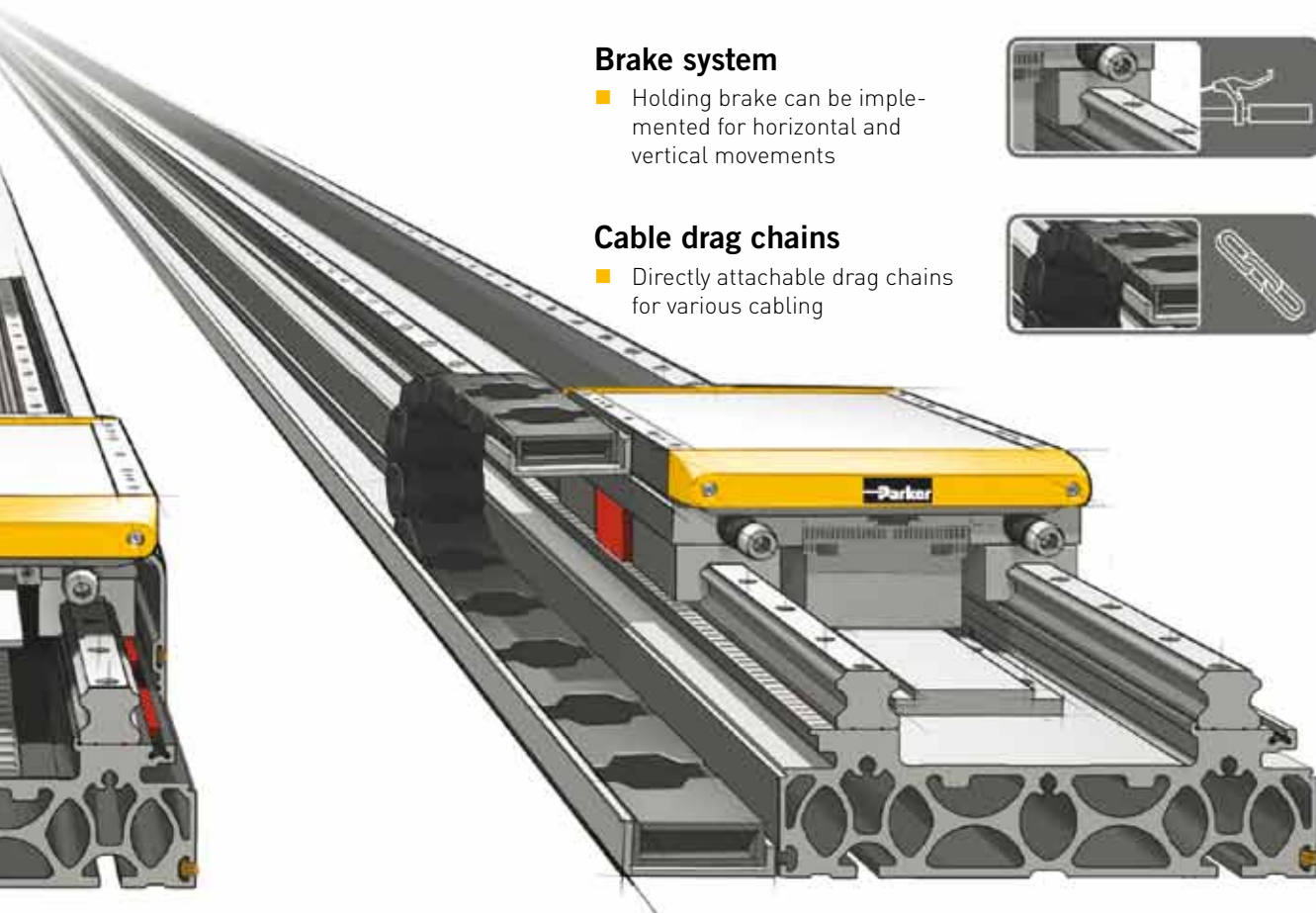

### Linear drive

The solution for fast travel with the greatest possible dynamics and precision

# ORIGA Linear Drives

HMR series

Profile versions

Sizes  
150, 180, 240 mm

## Designs

- Basic
- Reinforced

The HMR linear drive system can be equipped with a “basic” or “reinforced” profile as standard. The “basic” profile is suitable for fitting directly to a machine base that has a corresponding support surface. The “reinforced” profile, on the other hand, is the preferred choice for self-supporting systems or for use in conjunction with a base surface offering limited support.

“Basic” profile

“Reinforced” profile

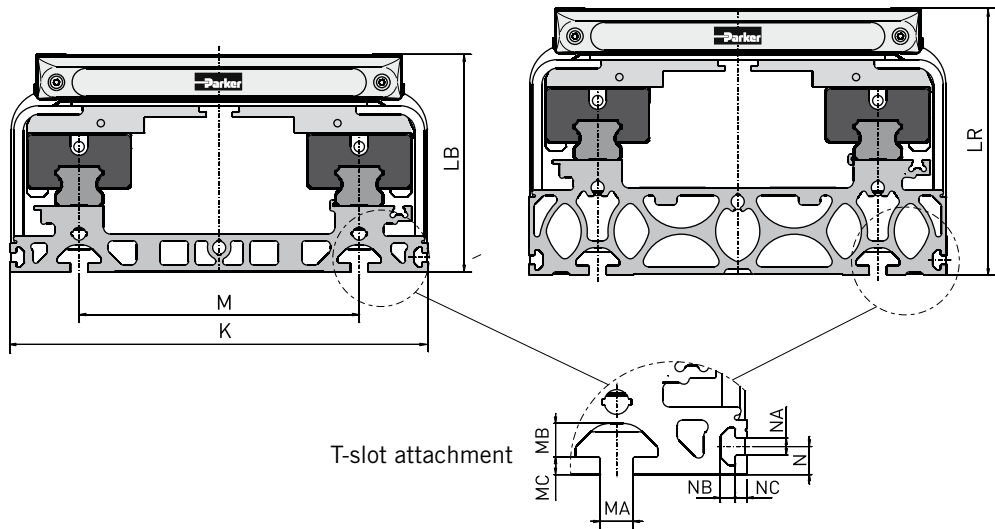

Dimension Table – Profile versions

Size	K	LB	LR	M	MA	MB	MC	N	NA	NB	NC
HMRx150	150.0	90.0	114.0	96.0	6.2	6.8	3.0	6.5	5.2	4.6	3.5
HMRx180	180.0	111.5	134.5	116.0	8.0	7.8	4.5	8.5	5.2	4.5	3.5
HMRx240	240.0	125.0	153.0	161.0	10.0	10.2	5.3	8.5	5.2	4.5	3.5

Dimensions in mm

## Loads, forces and bending moments

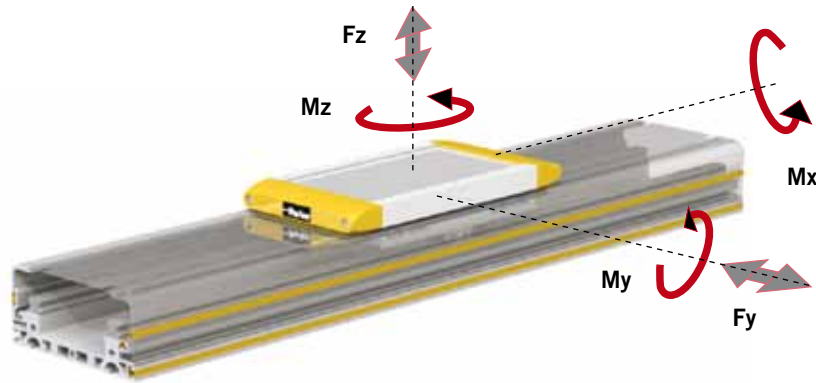

## ORIGA Linear Drives

HMR series

Ball bearing guide

Sizes  
150, 180, 240 mm

### Load requirements for guides and installation size.

The occurring loads, forces and bending moments depend on the application. The mass of the construction attached to the carriage has a center of gravity. This mass creates static forces ( $F = m \cdot g$ ) and bending moments ( $M = m \cdot g \cdot l$ ).

Additional dynamic moments ( $M = m \cdot a \cdot l$ ) arise in dependence of the acceleration during travel.

Care should be taken when selecting suitable guides that the permissible sum of loads does not exceed 1.

### Combined loads

The maximum permissible load for linear drives subject to simultaneous multiple

loads, forces and bending moments are calculated using the formula below.

Maximum permissible loads must not be exceeded.

$$L = \frac{F_y}{F_{y(max)}} + \frac{F_z}{F_{z(max)}} + \frac{M_x}{M_{x(max)}} + \frac{M_y}{M_{y(max)}} + \frac{M_z}{M_{z(max)}} \leq 1$$

The sum of all loads must under no circumstance be > 1.

### Internal lever arm $l_{zi}$

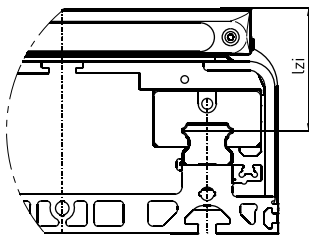

### Dimension table - $l_{zi}$

Product size		$l_{zi}$
HMR-150	[mm]	50.0
HMR-180	[mm]	57.5
HMR-240	[mm]	68.0

### Maximum permissible load based on a service life of 8000 km

Product size	HMRx15	HMRx18	HMRx24	HMRx15	HMRx18	HMRx24	
Carriage	Standard			Tandem			
<b>Max, permissible force</b>							
$F_{Z8000}$ $F_{Y8000}$	[N]	6,000	11,000	18,200	9,000	16,500	27,300
<b>Max. bending moment</b>							
$M_{X8000}$	[Nm]	290	640	1,460	435	960	2,190
$M_{Y8000}$	[Nm]	380	840	1,660	570	1,260	2,490
$M_{Z8000}$	[Nm]	380	840	1,660	570	1,260	2,490

### Maximum permissible load based on a service life of 2540 km

Product size	HMRx15	HMRx18	HMRx24	HMRx15	HMRx18	HMRx24	
Carriage	Standard			Tandem			
<b>Max. permissible force</b>							
$F_{Z2540}$ $F_{Y2540}$	[N]	8,800	16,200	26,600	13,200	24,300	39,900
<b>Max. bending moment</b>							
$M_{X2540}$	[Nm]	430	940	2,150	645	1,410	3,225
$M_{Y2540}$	[Nm]	560	1,230	2,430	840	1,845	3,645
$M_{Z2540}$	[Nm]	560	1,230	2,430	840	1,845	3,645



# HMRS Ball screw



# ORIGA Linear Drives

Series HMRS

Ball screw

Drive data

Sizes  
150, 180, 240 mm

## Technical Data HMRS

Product size				HMRS15		HMRS18		HMRS24	
Type of screw				20 x 5	20 x 20	25 x 10	25 x 25	32 x 10	32 x 32
Pitch	p	[mm]		5	20	10	25	10	32
Max. speed	v <sub>max.</sub>	[m/s]		0.25	1.00	0.50	1.25	0.50	1.60
Max. acceleration	a <sub>max.</sub>	[m/s <sup>2</sup> ]		10		10		10	
Repeatability			[μm]	± 20		± 20		± 20	
Max. order stroke			[mm]	2500		3400		4000	
<b>Thrust force and torque</b>									
Max. thrust force	F <sub>a max.</sub>	[N]		2600	2600	4800	4800	5500	5500
	F <sub>A2540</sub>	[N]		1800	2160	3300	3960	3500	4880
Max. torque at drive shaft	M <sub>a max.</sub>	[Nm]		2.2	9.0	8.3	20.8	9.5	30.4
	M <sub>A2540</sub>	[Nm]		1.6	7.5	5.7	17.1	6.1	27.0
No load torque	M <sub>0</sub>	[Nm]		0.7	0.9	0.9	1.0	1.0	1.1
<b>Stroke dependent speed</b>									
Max. permissible speed at order stroke	200 mm			250	1000	500	1250	500	1600
	400 mm			250	1000	500	1250	500	1600
	600 mm			250	1000	500	1250	500	1600
	800 mm			169	678	382	956	423	1354
	1000 mm			122	486	277	694	312	997
	1200 mm			91	366	211	526	239	765
	1400 mm			71	285	165	413	189	605
	1600 mm			57	228	133	333	153	491
	1800 mm			47	187	109	274	127	406
	2000 mm			39	156	92	229	107	342
	2200 mm			33	132	78	195	91	291
	2400 mm			28	113	67	167	79	251
	2600 mm			-	-	58	145	68	219
	2800 mm			-	-	51	128	60	193
	3000 mm			-	-	45	113	53	171
	3200 mm			-	-	40	100	48	152
3400 mm			-	-	-	-	43	137	
3600 mm			-	-	-	-	39	123	
3800 mm			-	-	-	-	35	112	
4000 mm			-	-	-	-	32	102	



**HMR-150 Performance / thrust force**

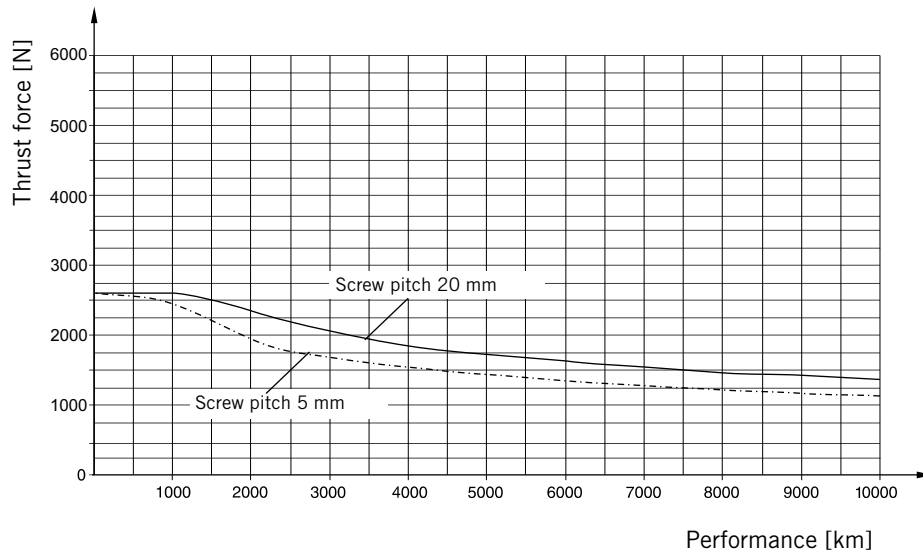

**ORIGA  
Linear Drives**

*Series HMRS*

*Ball screw*

*Performance / thrust force*

*Sizes  
150, 180, 240 mm*

Performance expectancy depends on the application's required force. An increase in force will reduce performance.

**HMR-180 Performance / thrust force**

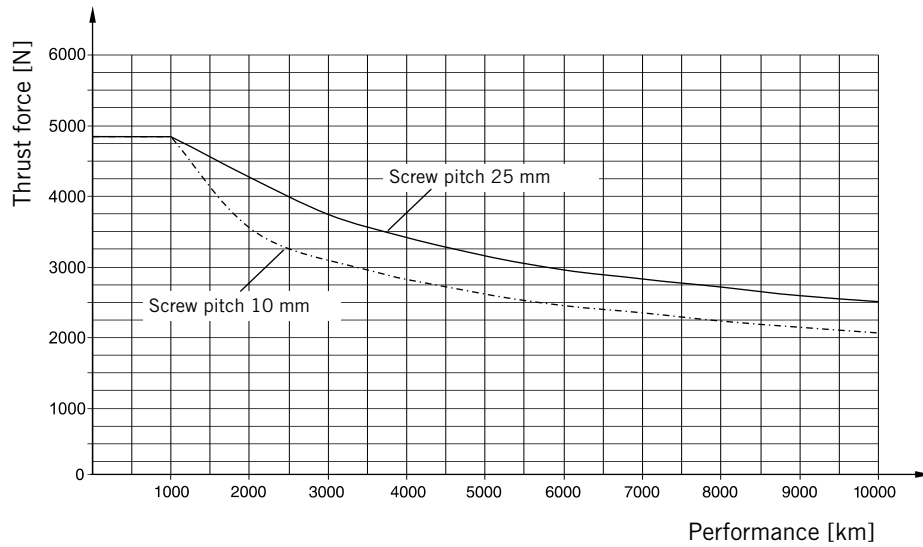

**HMR-240 Laufleistung / Aktionskraft**

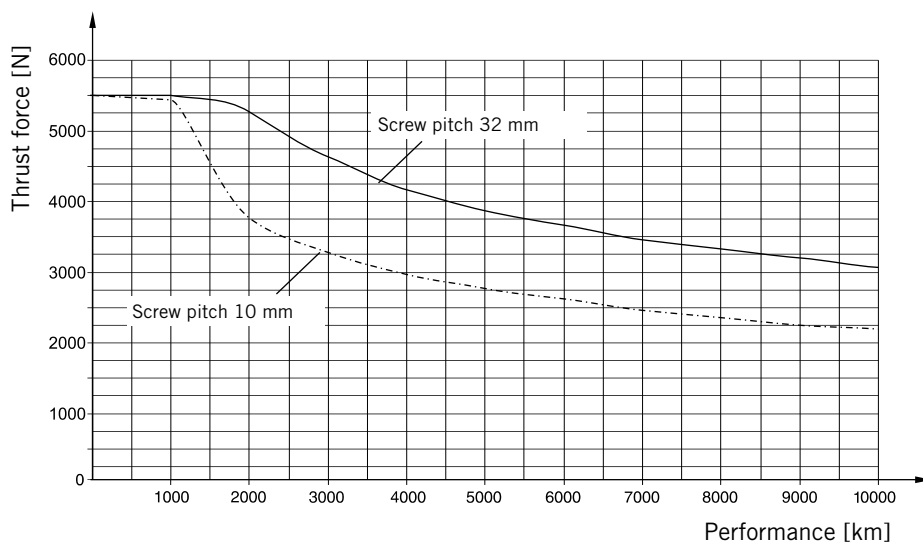

# ORIGA Linear Drives

Series HMRS

Ball screw

Dimensions

Sizes

150, 180, 240 mm

Basic dimensions

“Basic” profile

“Reinforced” profile

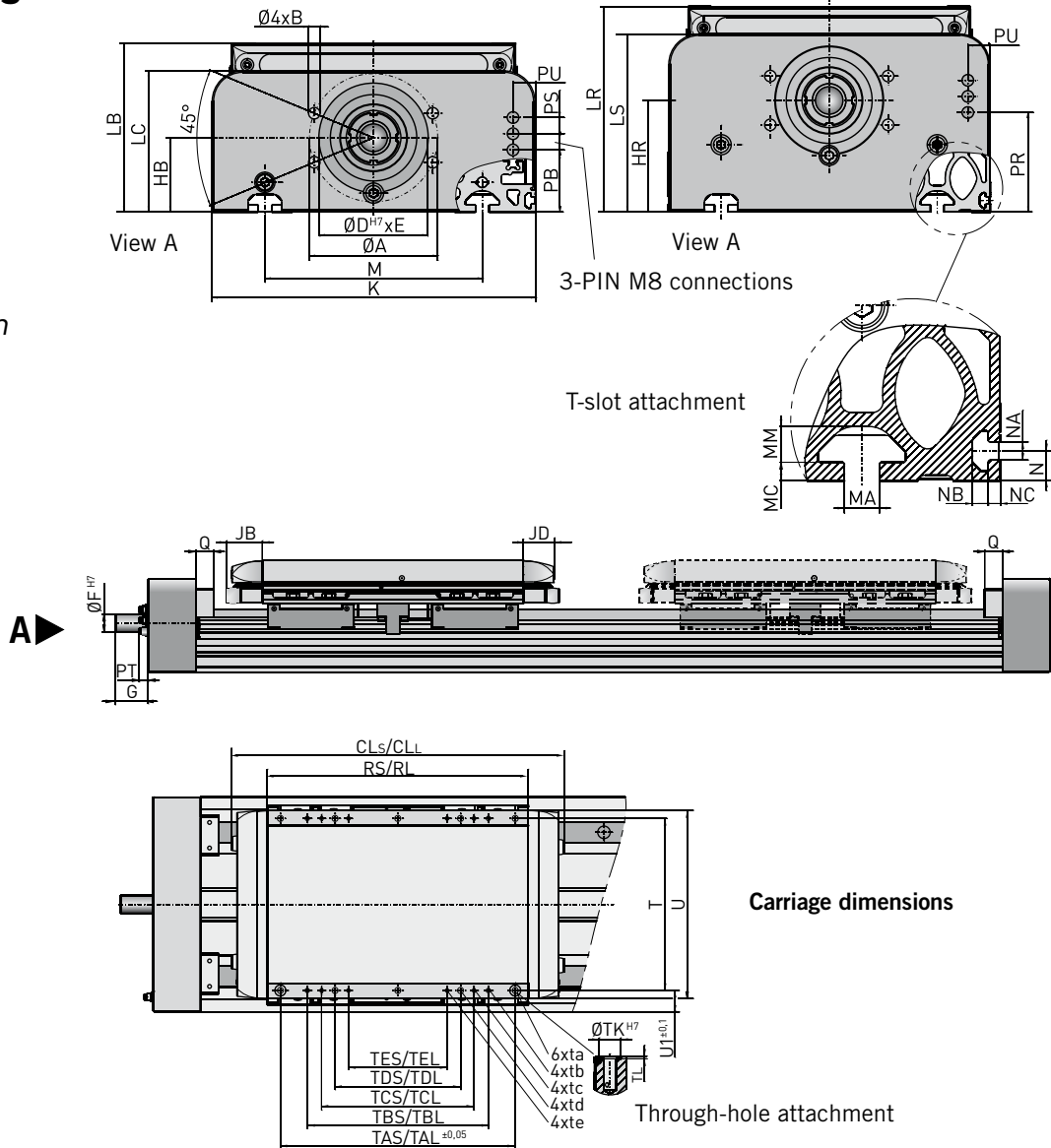

Dimension table - HMRS

Prod. size	ØA	B	ØD <sup>H7</sup>	E	ØF <sup>H7</sup>	G	HB	HR	K	LB	LC	LR	LS
HMRS15	72.0	M8	54.0	4.0	12.0	31.0	36.0	60.0	150.0	90.0	74.0	114.0	98.0
HMRS18	80.0	M8	64.0	2.5	15.0	33.0	44.0	67.5	180.0	111.5	93.5	134.5	116.5
HMRS24	95.0	M10	80.0	2.5	20.0	37.0	55.0	83.0	240.0	125.0	104.5	153.0	132.5

Prod. size	M	MA	MB	MC	N	NA	NB	NC	PB	PR	PS	PT	PU	Q
HMRS15	96.0	6.2	6.8	3.0	6.5	5.2	4.6	3.5	15.0	39.0	12.0	9.0	15.0	20.0
HMRS18	116.0	8.0	7.8	4.5	8.5	5.2	4.5	3.5	28.0	51.0	12.0	9.0	18.0	20.0
HMRS24	161.0	10.0	10.2	5.3	8.5	5.2	4.5	3.5	46.0	74.0	12.0	9.0	16.5	20.0

Dimension table - carriage standard HMRS

Prod. size	JB	JD	CL <sub>S</sub>	RS	T	TAS	ta	TBS	tb	TCS	tc	TDS	td	TES	te	ØTK <sup>H7</sup>	TL	U	U1
HMRS15	37.5	34	266	191	120	170	M5x12	110	M5x12	-	-	70	M5x12	-	-	7	1.5	135	15
HMRS18	40.0	34	311	231	150	202	M6x12	170	M5x10	110	M5x10	90	M6x12	-	-	9	1.5	165	15
HMRS24	40.0	34	371	291	192	262	M8x16	202	M6x12	170	M5x10	140	M8x16	110	M5x10	12	1.5	210	24

Dimensions in mm

# ORIGA Linear Drives

Series HMRS

Weight, mass and  
inertia

## Weight and mass HMRS

Product size			HMRS15				HMRS18				HMRS24			
<b>Weight of actuator</b>														
Version of actuator (see order code)			B	C	R	S	B	C	R	S	B	C	R	S
Weight actuator. 0 - order stroke	$m_0$	[kg]	5.2	6.1	7.1	7.9	8.9	10	11.2	12.3	16.5	18.1	20.5	22.2
Weight actuator per 1 meter	$m_{mt}$	[kg/m]	12.1	13.9	15.5	17.2	15.5	17.7	19.1	21.4	25.6	28.3	30.7	33.4
<b>Moving mass</b>														
Version of carriage (see order code)			0	1	0	1	0	1	0	1	0	1		
Weight actuator	$m_c$	[kg]	2.6	1.8	4.7	3.7	9.2	7.3						

Total mass HMRS:  $m_{tot} = m_0 + m_c + \text{order stroke} * m_{mt}$

## Inertia HMRS

Product size			HMRS15		HMRS18		HMRS24	
Pitch (see order code)			5	20	10	25	10	32
Inertia actuator. 0 - order stroke	$J_0$	[kgmm <sup>2</sup> ]	14		35		96	
Inertia actuator per 1 meter	$J_{mt}$	[kgmm <sup>2</sup> /m]	107		245		639	
Inertia per 1 kg moving mass	$J_{kg}$	[kgmm <sup>2</sup> /kg]	0.6	10.1	2.5	15.8	2.5	25.9

Total inertia HMRS:  $J_{tot} = J_0 + \text{order stroke} * J_{mt} + m_c * J_{kg} + m * J_{kg}$



# ORIGA Linear Drives

Series HMRS

Ball screw

Order stroke

Sizes

150, 180, 240 mm

## Order stroke dependent dimensions

- ES = Effective Stroke
- SS = Safety Stroke
- CD = Carriage distance
- CL<sub>S</sub> = Carriage length Standard
- CL<sub>L</sub> = Carriage length long
- S = Stroke
- OS = Order Stroke
- OAL = Over All Length

### Standard design with one carriage

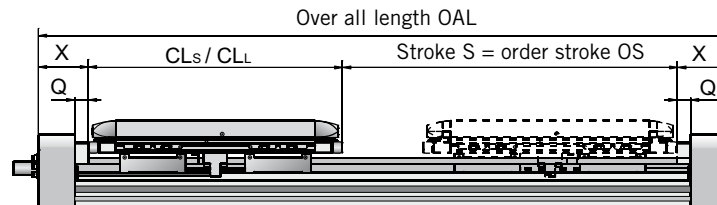

Order stroke OS = Effective stroke ES + 2 x Safety stroke SS

Over all length OAL = order stroke OS + carrier length CL + 2 x dimension end cap X

### Tandem design with two carriages

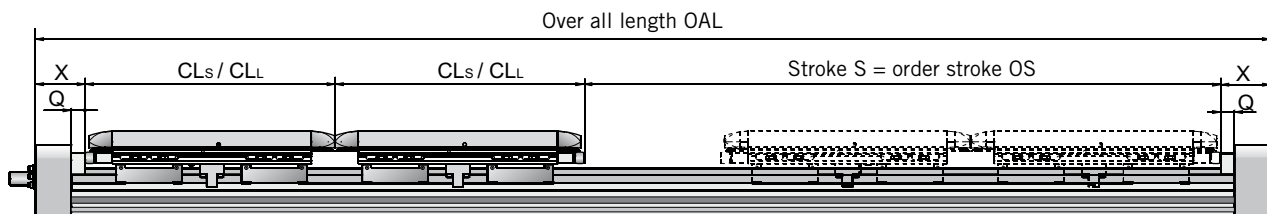

Order stroke OS = Effective stroke ES + 2 x Safety stroke SS + Carrier distance CD (not shown)

Over all length OAL = Order stroke OS + 2 x carrier length CL + 2 x dimension end cap X

### Dimensions - Carriage and end cap HMRS

Product size	CL <sub>S</sub>	CL <sub>L</sub>	Q	X
HMRS15	266.0	-	20.0	62.0
HMRS18	311.0	-	20.0	66.0
HMRS24	371.0	-	20.0	73.0

Dimensions in mm





# ORIGA Linear Drives

## Series HMRS

Order code		HMR	S	15	B	05	0	-	0000	-	0	0	0	0	0	00	00
<b>Type of actuator</b>																	
S	Ball screw drive																
<b>Product size</b>																	
15	Product width 150 mm																
18	Product width 180 mm																
24	Product width 240 mm																
<b>Actuator design</b>																	
B	Basic Profile with ball bearing guide and IP20 without cover																
C	Basic Profile with ball bearing guide and IP54 with outer cover																
R	Reinforced Profile with ball bearing guide and IP20 without cover																
S	Reinforced Profile with ball bearing guide and IP54 with outer cover																
<b>Pitch</b>																	
<b>Product size HMRS</b>		<b>15</b>	<b>18</b>	<b>24</b>													
05	Pitch 5 mm with plane drive shaft	<input checked="" type="checkbox"/>															
10	Pitch 10 mm with plane drive shaft		<input checked="" type="checkbox"/>	<input checked="" type="checkbox"/>													
20	Pitch 20 mm with plane drive shaft	<input checked="" type="checkbox"/>															
25	Pitch 25 mm with plane drive shaft		<input checked="" type="checkbox"/>														
32	Pitch 32 mm with plane drive shaft			<input checked="" type="checkbox"/>													
<b>Carriage</b>																	
0	Standard																
1	Tandem																
<b>Order stroke</b>																	
0000	4 digits input in mm																
<b>Reference switch (one switch)</b>																	
0	Without																
1	R2NO-I: Reed, 2-wire, NO, internal																
A	P3NO-I: PNP, 3-wire, NO, internal																
3	R2NO-P: Reed, 2-wire, NO, M8 plug, 0,3 m cable, external																
5	R2NO-C5: Reed, 2-wire, NO, flying leads, 3 m cable, external																
C	P3NO-P: PNP, 3-wire, NO, M8 plug, 0,3 m cable, external																
E	P3NO-C5: PNP, 3-wire, NO, flying leads, 3 m cable, external																
<b>End position switch (one switch per end position)</b>																	
0	Without																
2	R2NC-I: Reed, 2-wire, NC, internal																
B	P3NC-I: PNP, 3-wire, NC, internal																
4	R2NC-P: Reed, 2-wire, NC, M8 plug, 0.3m cable, external																
6	R2NC-C5: Reed, 2-wire, NC, flying leads, 3m cable, external																
D	P3NC-P: PNP, 3-wire, NC, M8 plug, 0.3m cable, external																
F	P3NC-C5: PNP, 3-wire, NC, flying leads, 3m cable, external																
<b>Positioning of Magnetic Sensors</b>																	
0	Without sensor																
1	10 mm																
2	20 mm																
	:																
A	100 mm																
B	110 mm																
	:																
H	170 mm																
J	180 mm																
K	190 mm																
L	200 mm																



### Mounting Kit\* or Motor mounting

Product size HMRS		15	18	24			
00	Without mounting kit or motor mounting	<input checked="" type="checkbox"/>	<input checked="" type="checkbox"/>	<input checked="" type="checkbox"/>			

### Mounting Kit Gear

A7	PS60	<input checked="" type="checkbox"/>	<input checked="" type="checkbox"/>				
A8	PS90		<input checked="" type="checkbox"/>				
A9	PS115			<input checked="" type="checkbox"/>			
C1	PV60-TA / LP070	<input checked="" type="checkbox"/>	<input checked="" type="checkbox"/>				
C2	PV90-TA / LP090		<input checked="" type="checkbox"/>				
C3	PV115-TA / LP120			<input checked="" type="checkbox"/>			

### Mounting kit Motor

Size	Gear mounting	15	18	24	Bx	Cx	Dx
A2	SMx60 8/11, MH56 5/11, NX2	<input checked="" type="checkbox"/>			<input checked="" type="checkbox"/>		
A3	SMx82 8/14	<input checked="" type="checkbox"/>	<input checked="" type="checkbox"/>		<input checked="" type="checkbox"/>	<input checked="" type="checkbox"/>	
A4	SMx100 5/19, MH105 5/19	<input checked="" type="checkbox"/>	<input checked="" type="checkbox"/>	<input checked="" type="checkbox"/>		<input checked="" type="checkbox"/>	<input checked="" type="checkbox"/>
A5	SMx115 5/24, SMx142 5/24, MH145 5/24		<input checked="" type="checkbox"/>	<input checked="" type="checkbox"/>		<input checked="" type="checkbox"/>	<input checked="" type="checkbox"/>

\* Mounting kit: contains gear housing, motor coupling and flange

### Guide mounting

Product size HMRS		15	18	24			
00	Without	<input checked="" type="checkbox"/>	<input checked="" type="checkbox"/>	<input checked="" type="checkbox"/>			
B1	LP070 i = 3	<input checked="" type="checkbox"/>	<input checked="" type="checkbox"/>				
B2	LP070 i = 5	<input checked="" type="checkbox"/>	<input checked="" type="checkbox"/>				
B3	LP070 i = 10	<input checked="" type="checkbox"/>	<input checked="" type="checkbox"/>				
C1	LP090 i = 3		<input checked="" type="checkbox"/>				
C2	LP090 i = 5		<input checked="" type="checkbox"/>				
C3	LP090 i = 10		<input checked="" type="checkbox"/>				
D1	LP120 i = 3			<input checked="" type="checkbox"/>			
D2	LP120 i = 5			<input checked="" type="checkbox"/>			
D3	LP120 i = 10			<input checked="" type="checkbox"/>			



# HMRB Belt

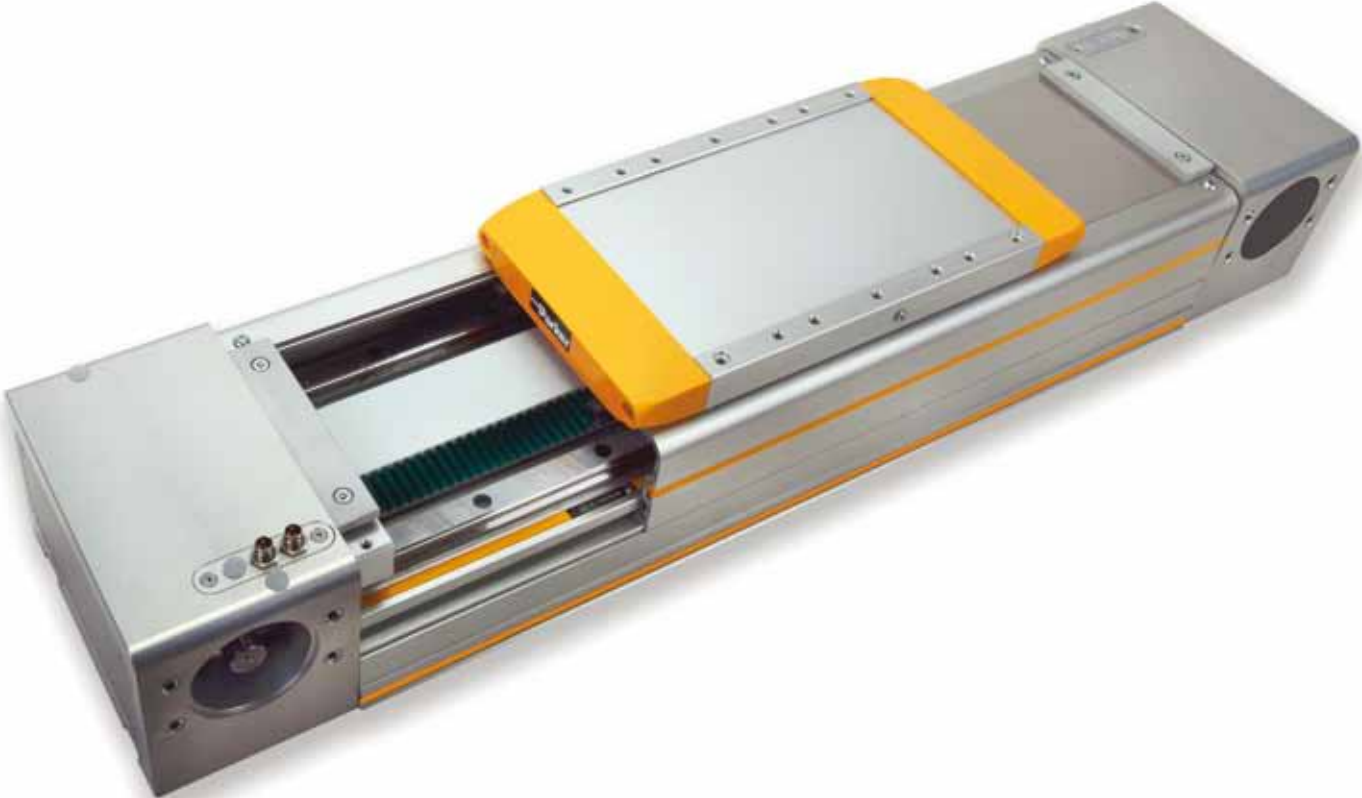

# ORIGA Linear Drives



Series HMRB

Belt

Drive data

Sizes  
150, 180, 240 mm

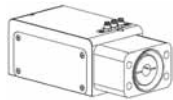
## Description Motor mounting position

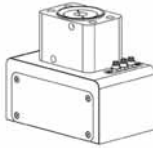
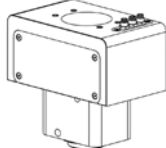
			
<b>horizontal</b>		<b>upright</b>	
<b>090° / 270°</b>		<b>000° / 180°</b>	
<b>BD, DD</b>		<b>AP, CP, AD, CD</b>	

Type and orientation of the belt is given by the motor mounting position.

## Technical data HMRB

Production size			HMRB15	
<b>Motor mounting position</b>			090°/270°	000°/180°
Lead constant	$s_{lin.}$	[mm]	100	125
Max. speed	$v_{max.}$	[m/s]	5	
Max. acceleration	$a_{max.}$	[m/s <sup>2</sup> ]	50	
Repeatability		[μm]	±50	
Max. order stroke		[mm]	6000	
<b>Thrust force and torque</b>				
Max. thrust force	$F_{A max.}$	[N]	1050	630
Max. torque on drive shaft	$M_{A max.}$	[Nm]	17	13
No load torque	$M_0$	[Nm]	1,2	1,2
Production size			HMRB18	
<b>Motor mounting position</b>			090°/270°	000°/180°
Lead constant	$s_{lin.}$	[mm]	130	150
Max. speed	$v_{max.}$	[m/s]	5	
Max. acceleration	$a_{max.}$	[m/s <sup>2</sup> ]	50	
Repeatability		[μm]	±50	
Max. order stroke		[mm]	6000	
<b>Thrust force and torque</b>				
Max. thrust force	$F_{A max.}$	[N]	1300	1000
Max. torque on drive shaft	$M_{A max.}$	[Nm]	27	24
No load torque	$M_0$	[Nm]	2,0	2,0
Production size			HMRB24	
<b>Motor mounting position</b>			090°/270°	000°/180°
Lead constant	$s_{lin.}$	[mm]	160	224
Max. speed	$v_{max.}$	[m/s]	5	
Max. acceleration	$a_{max.}$	[m/s <sup>2</sup> ]	50	
Repeatability		[μm]	±50	
Max. order stroke		[mm]	6000	
<b>Thrust force and torque</b>				
Max. thrust force	$F_{A max.}$	[N]	4000	3750
Max. torque on drive shaft	$M_{A max.}$	[Nm]	101	134
No load torque	$M_0$	[Nm]	4,0	4,0



## Valid action forces HMRB

Version motor mounting position				
Product size			HMRB15	
Motor mounting position			090°/270°	000°/180°
Thrust force $F_A$ corresponding to speed $v$	$F_{v<1}$	[N]	1050	630
	$F_{v<2}$	[N]	990	630
	$F_{v<3}$	[N]	930	630
	$F_{v<4}$	[N]	890	630
	$F_{v<5}$	[N]	840	630
Thrust force $F_A$ corresponding to order stroke length OS	$F_{A(OS<1000)}$	[N]	1050	630
	$F_{A(OS<2000)}$	[N]	820	490
	$F_{A(OS<3000)}$	[N]	570	340
	$F_{A(OS<4000)}$	[N]	445	265
	$F_{A(OS<5000)}$	[N]	365	215
$F_{A(OS<6000)}$	[N]	305	185	
Product size			HMRB18	
Motor mounting position			090°/270°	000°/180°
Thrust force $F_A$ corresponding to speed $v$	$F_{v<1}$	[N]	1300	1000
	$F_{v<2}$	[N]	1300	1000
	$F_{v<3}$	[N]	1300	1000
	$F_{v<4}$	[N]	1300	1000
	$F_{v<5}$	[N]	1300	1000
Thrust force $F_A$ corresponding to order stroke length OS	$F_{A(OS<1000)}$	[N]	1300	1000
	$F_{A(OS<2000)}$	[N]	1000	775
	$F_{A(OS<3000)}$	[N]	710	550
	$F_{A(OS<4000)}$	[N]	550	430
	$F_{A(OS<5000)}$	[N]	450	350
$F_{A(OS<6000)}$	[N]	380	295	
Product size			HMRB24	
Motor mounting position			090°/270°	000°/180°
Thrust force $F_A$ corresponding to speed $v$	$F_{v<1}$	[N]	4000	3750
	$F_{v<2}$	[N]	4000	3380
	$F_{v<3}$	[N]	3650	3140
	$F_{v<4}$	[N]	3370	2950
	$F_{v<5}$	[N]	3200	2800
Thrust force $F_A$ corresponding to order stroke length OS	$F_{A(OS<1000)}$	[N]	4000	3750
	$F_{A(OS<2000)}$	[N]	4000	3360
	$F_{A(OS<3000)}$	[N]	3370	2440
	$F_{A(OS<4000)}$	[N]	2860	1880
	$F_{A(OS<5000)}$	[N]	2350	1540
$F_{A(OS<6000)}$	[N]	2000	1300	

## ORIGA Linear Drives

Series HMRB

Belt

Action force

Sizes  
150, 180, 240 mm

The permissible thrust force from the table is depending on speed level and order stroke length.

The minimum thrust force value must not be exceeded in the application.

Information:  
Limiting the torque from the motor may avoid exceeding permitted thrust force.

**Example:**  
HMRB18 with motor mounting position 1 (090° front), speed  $v = 2$  m/s ( $F = 710$  N) and order stroke length OS ( $F = 1.088$  N).  
The maximum permissible thrust force  $F = 710$  N must not be exceeded.



# ORIGA Linear Drives

Series HMRB

Belt

Dimensions

Sizes  
150 180, 240 mm

## Dimensions

“Basic” profile

“Reinforced” profile

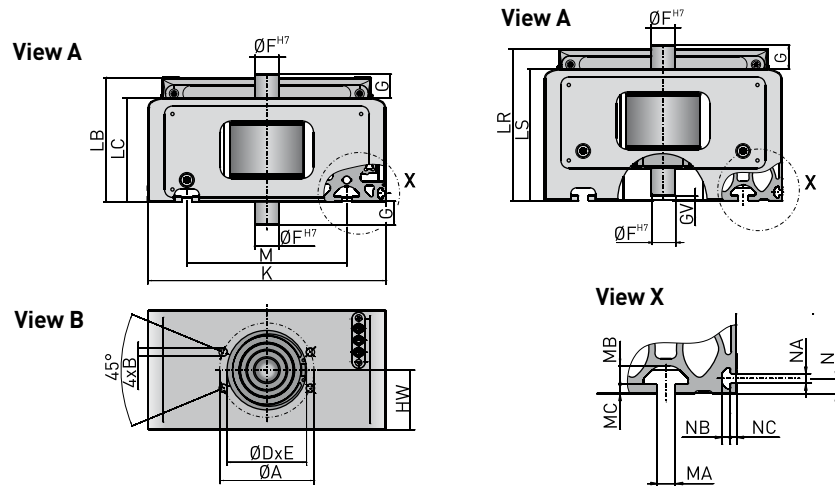

## Dimensions carrier

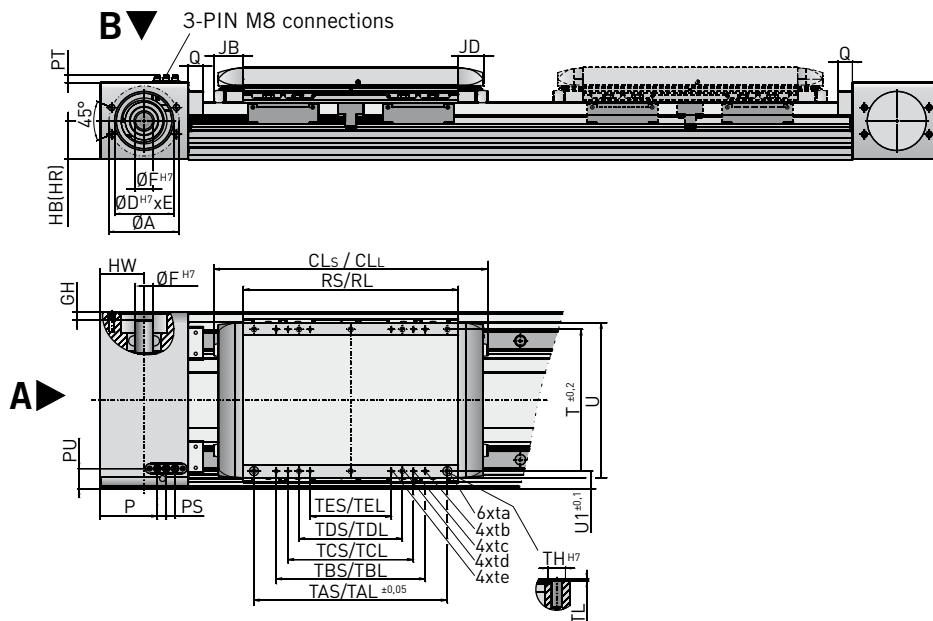

## Dimension table - HMRB

Size	Ø A	B	Ø D <sup>H7</sup>	E	Ø F <sup>H7</sup>	G	GV	GH	HB	HR	HW	K	LB	LC	
HMRB15	72	M8	54	2.1	15	19.3	7.0	5.5	36.5	60.5	45	150	90.0	74.0	
HMRB18	80	M8	64	4.0	18	21.8	1.5	8.0	45.0	68.0	50	180	111.5	93.5	
HMRB24	95	M10	80	2.5	24	24.0	4.0	11.0	52.5	80.5	60	240	125.0	104.5	
	LR	LS	M	MA	MB	MC	N	NA	NB	NC	P	PS	PT	PU	Q
HMRB15	114.0	98.0	96	6.2	6.8	3.0	6.5	5.2	4.6	3.5	48	12	9	21.0	20
HMRB18	134.5	116.5	116	8.0	7.8	4.5	8.5	5.2	4.5	3.5	58	12	9	28.0	20
HMRB24	153.0	132.5	161	10.0	10.2	5.3	8.5	5.2	4.5	3.5	78	12	9	28.6	20

## Dimension table - carrier standard HMRB

Size	JB	JD	JS	RS	T	TAS	ta	TBS	tb	TCS	tc	TDS	td	TES	te	ØTK <sup>H7</sup>	TL	U	U1
HMRB15	37.5	37.5	260	191	120	170	M5x12	110	M5x12	-	-	70	M5x12	-	-	7	1.5	135	15
HMRB18	40.0	40.0	300	231	150	202	M6x12	170	M5x10	110	M5x10	90	M6x12	-	-	9	1.5	165	15
HMRB24	40.0	40.0	360	291	192	262	M8x16	202	M6x12	170	M5x10	140	M8x16	110	M5x10	12	1.5	210	24

Dimensions in mm

# ORIGA Linear Drives

Series HMRB  
Weight, mass and  
inertia

## Weight and mass HMRB

Product size		HMRB15				HMRB18				HMRB24				
Version actuator (see order code)		B	C	R	S	B	C	R	S	B	C	R	S	
<b>Weight of actuator</b>														
Weight, 0 - order stroke		$m_0$ [kg]	6.7	7.5	9.4	10.3	11.6	12.8	15.6	16.7	21.5	23.1	28.0	29.6
Weight per 1 m order stroke		$m_{mt}$ [kg/m]	8.2	9.9	11.5	13.3	12.8	15.1	16.5	18.7	21.6	24.4	26.7	29.5
<b>Moving mass carrier</b>														
Version of carrier (see order code)		0	1	0	1	0	1	0	1	0	1	0	1	
Weight carrier		$m_c$ [kg]	2.7	1.9	4.6	3.7	9.0	7.2						

Total mass HMRB:  $m_{tot} = m_0 + m_c + \text{order stroke} * m_{mt}$

Inertia HMRB								
Product size		HMRB15		HMRB18		HMRB24		
Motor mounting position (see order code)		090°/270°	000°/180°	090°/270°	000°/180°	090°/270°	000°/180°	
<b>Inertia</b>								
Inertia 0 - order stroke		$J_0$ [kgmm <sup>2</sup> ]	102	145	297	394	1178	2758
Inertia per 1 m order stroke		$J_{mt}$ [kgmm <sup>2</sup> /m]	79	79	134	222	689	900
Inertia per 1 kg moving mass		$J_{kg}$ [kgmm <sup>2</sup> /kg]	253	396	428	570	649	1271

Inertia total HMRB:  $J_{tot} = J_0 + \text{order stroke} * J_{mt} + m_c * J_{kg} + m * J_{kg}$



# ORIGA Linear Drives

Series HMRB

Belt

Order stroke

Sizes

150, 180, 240 mm

## Stroke depending dimensions

- ES = Effective Stroke
- SS = Safety Stroke
- CD = Carriage distance
- CL<sub>S</sub> = Carriage length Standard
- CL<sub>L</sub> = Carriage length long
- S = Stroke
- OS = Order Stroke
- OAL = Over All Length

## Option Carrier Standard

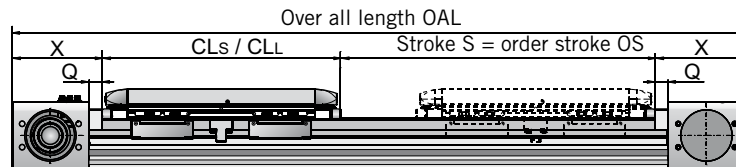

Order stroke OS = Effective stroke ES + 2 x Safety stroke SS

Over all length OAL = Order stroke OS + Carrier length CL + 2 x End cap length X

## Option Carrier Tandem

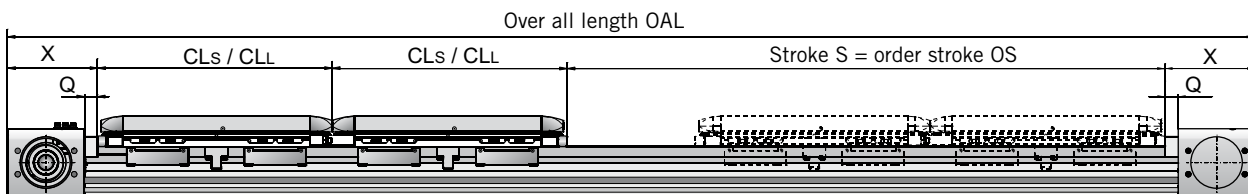

Order stroke OS = Effective stroke ES + 2 x Safety stroke SS + Carrier distance CD (not shown)

Over all length OAL = Order stroke OS + 2 x Carrier length CL + 2 x End cap length X

## Option Carrier Bi-part for opposite movements

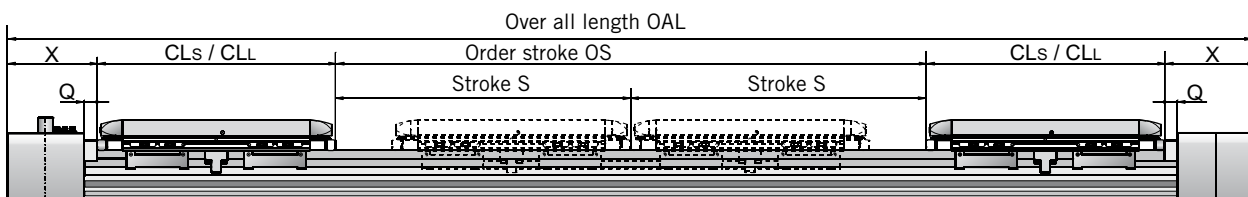

Order stroke OS = 2 x Stroke S = 2 x Effective stroke ES + 4 x Safety stroke SS + Carrier distance CD (not shown)

Over all length OAL = Order stroke OS + 2 x Carrier length CL + 2 x End cap length X

## Dimensions - Carriage and end cap HMRB

Product size	CL <sub>S</sub>	CL <sub>L</sub>	Q	X
HMRB15	266.0	-	20.0	110.0
HMRB18	311.0	-	20.0	120.0
HMRB24	371.0	-	20.0	140.0



Dimensions in mm



# ORIGA Linear Drives

## Product series HMRB

Order code		HMR	B	15	B	05	0	-	0000	-	0	0	0	0	0	00	00
<b>Type of actuator</b>			↑														
B	Belt																
<b>Product size</b>				↑													
15	Product width 150 mm																
18	Product width 180 mm																
24	Product width 240 mm																
<b>Actuator design</b>					↑												
B	Basic Profile with ball bearing guide and IP20 without cover																
C	Basic Profile with ball bearing guide and IP54 with outer cover																
R	Reinforced Profile with ball bearing guide and IP20 without cover																
S	Reinforced Profile with ball bearing guide and IP54 with outer cover																
<b>Motor mounting position and drive shaft design</b>																	
BD	090° front with double plain shaft																
DD	270° back with double plain shaft																
AP	000° up with single plain shaft																
CP	180° down with single plain shaft																
AD	000° up with double plain shaft																
CD	180° down with double plain shaft																
<b>Carriage design</b>																	
0	Standard																
1	Tandem																
2	Bi-part																
<b>Order stroke</b>																	
0000	4 digits input in mm																
<b>Home Sensor (one sensor)</b>																	
0	No home sensor																
1	R2NO-I: Reed, 2 wire, normally open, Internal																
A	N3NO-I: NPN, 3 wire, normally open, Internal																
3	R2NO-P: Reed, 2 wire, normally open, M8 plug, 0.3 m cable, External																
5	R2NO-C5: Reed, 2 wire, normally open, Flying leads, 3 m cable, external																
C	N3NO-P: NPN, 3 wire, normally open, M8 plug, 0.3 m cable, external																
E	N3NO-C5: NPN, 3 wire, normally open, Flying leads, 3 m cable, external																
<b>Limit Sensor (one sensor each end)</b>																	
0	No limit sensor																
2	R2NC-I: Reed, 2 wire, normally close, Internal																
B	N3NC-I: NPN, 3 wire, normally close, Internal																
4	R2NC-P: Reed, 2 wire, normally close, M8 plug, 0.3 m cable, external																
6	R2NC-C5: Reed, 2 wire, normally close, Flying leads, 3 m cable, external																
D	N3NC-P: NPN, 3 wire, normally close, M8 plug, 0.3 m cable, external																
F	N3NC-C5: NPN, 3 wire, normally close, Flying leads, 3 m cable, external																
<b>Mounting position limit sensor</b>																	
0	No limit sensor																
1	10 mm																
2	20 mm																
	⋮																
A	100 mm																
B	110 mm																
	⋮																
H	170 mm																
J	180 mm																
K	190 mm																
L	200 mm																

<b>Mounting kit * or motor mounting</b>							
<b>Product size HMRS</b>		<b>15</b>	<b>18</b>	<b>24</b>			
00	No mounting kit or motor mounting	<input checked="" type="checkbox"/>	<input checked="" type="checkbox"/>	<input checked="" type="checkbox"/>			
<b>Mounting kit Gear</b>		<b>15</b>	<b>18</b>	<b>24</b>			
A7	PS60	<input checked="" type="checkbox"/>	<input checked="" type="checkbox"/>				
A8	PS90		<input checked="" type="checkbox"/>				
A9	PS115			<input checked="" type="checkbox"/>			
C1	PV60-TA / LP070	<input checked="" type="checkbox"/>	<input checked="" type="checkbox"/>				
C2	PV90-TA / LP090		<input checked="" type="checkbox"/>				
C3	PV115-TA / LP120			<input checked="" type="checkbox"/>			
<b>Mounting kit Motor</b>							
Size	Gear mounting	<b>15</b>	<b>18</b>	<b>24</b>	<b>Bx</b>	<b>Cx</b>	<b>Dx</b>
A2	SMx60 8/11, MH56 5/11, NX2	<input checked="" type="checkbox"/>			<input checked="" type="checkbox"/>		
A3	SMx82 8/14	<input checked="" type="checkbox"/>	<input checked="" type="checkbox"/>		<input checked="" type="checkbox"/>	<input checked="" type="checkbox"/>	
A4	SMx100 5/19, MH105 5/19	<input checked="" type="checkbox"/>	<input checked="" type="checkbox"/>	<input checked="" type="checkbox"/>		<input checked="" type="checkbox"/>	<input checked="" type="checkbox"/>
A5	SMx115 5/24, SMx142 5/24, MH145 5/24		<input checked="" type="checkbox"/>	<input checked="" type="checkbox"/>		<input checked="" type="checkbox"/>	<input checked="" type="checkbox"/>

\* Mounting kit, consisting coupling housing, motor coupling and flange

<b>Gear mounting</b>						
<b>Product size HMRB</b>		<b>15</b>	<b>18</b>	<b>24</b>		
00	No Gear mounting	<input checked="" type="checkbox"/>	<input checked="" type="checkbox"/>	<input checked="" type="checkbox"/>		
B1	LP070 i = 3	<input checked="" type="checkbox"/>	<input checked="" type="checkbox"/>			
B2	LP070 i = 5	<input checked="" type="checkbox"/>	<input checked="" type="checkbox"/>			
B3	LP070 i = 10	<input checked="" type="checkbox"/>	<input checked="" type="checkbox"/>			
C1	LP090 i = 3		<input checked="" type="checkbox"/>			
C2	LP090 i = 5		<input checked="" type="checkbox"/>			
C3	LP090 i = 10		<input checked="" type="checkbox"/>			
D1	LP120 i = 3			<input checked="" type="checkbox"/>		
D2	LP120 i = 5			<input checked="" type="checkbox"/>		
D3	LP120 i = 10			<input checked="" type="checkbox"/>		



# HMR Options



# ORIGA Linear Drives

*HMR series*

*Option*

*Protection Class*

**Versions:**

**IP20 – without cover**

**IP54 – with cover**

HMR got developed for various environment conditions. The basic design has an IP20 protection class.

HMR can be equipped with a cover to correspond to an IP54 protection class if a higher rating is required.

Version – protection class IP20



Version – protection class IP54



### Shock absorbers for impact protection

Product size		HMRx15	HMRx18	HMRx24
Shock absorber		TA12-5	TA17-7	TA17-7
Energy absorption	[Nm/stroke]	3.0	8.5	8.5
Maximum stroke	[mm]	5.0	7.0	7.0

## ORIGA Linear Drives

*HMR series*

*Option*

*Impact protection*

### Distance-force and energy-distance characteristic curve (dynamic) – production size HMR-145

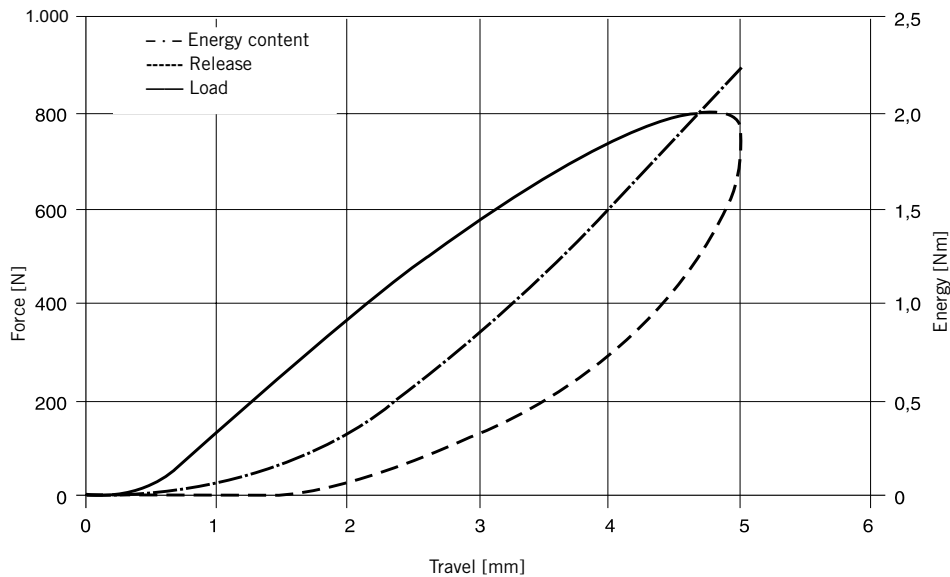

HMR can be equipped with impact protection. The mounted structure shock absorbers can compensate the energy released by unintentional impact and afford protection against mechanical damage.

Two structure shock absorbers are fitted to each side of the carriage prior to delivery.

### Distance-force and energy-distance characteristic curve (dynamic) – production size HMR-175, HMR-225

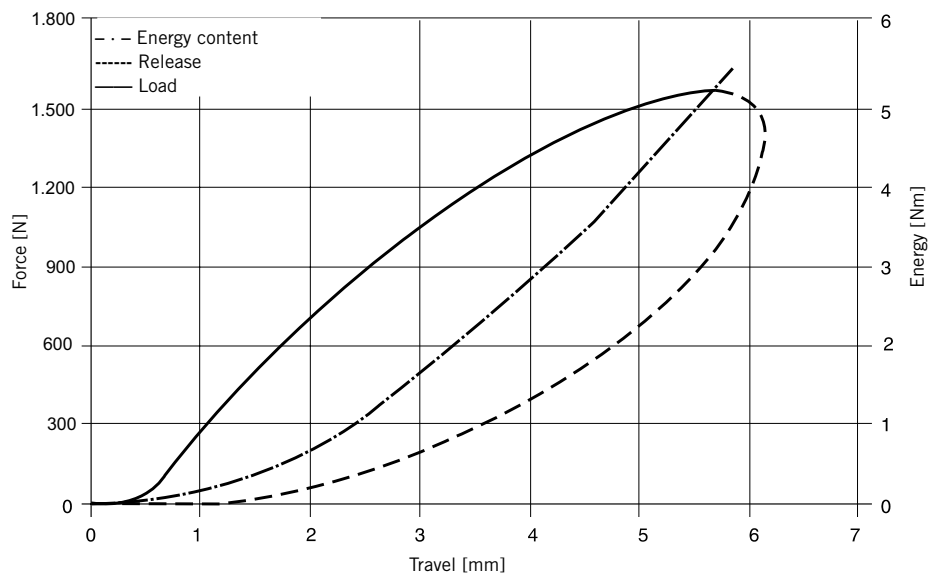

# ORIGA Linear Drives

HMR series

Option

Position detection

**Magnetic switches for:**

– End positions

– Homing

### Type P8S

The new generation of t-slot sensors convince with easy mounting avoiding special tools and with a drop in moutange. Due to new electronic the hysteresis is very small and allows a very accurate switching point.

Magnetic sensors are used for contactless electric sensing of the carrier position, e.g. for end or homing positions of a linear acutator. The field of magnets mounted as standard into the carriage activate the sensor..

**The possible speed of the load-bearing element or carriage must take the minimum response time of downstream devices into account.**

**Contact travel is considered accordingly in the calculations.**

$$\text{Minimum response time} = \frac{\text{Contact travel}}{\text{Overrun speed}}$$

Technical Data	Unit	P8S-GR P8S-GE	P8S-GP P8S-GQ P8S-GN P8S-GM
Magnetic Sensor			
<b>Electrical specifications</b>			
Switch output / -function		Reed / NO Reed / NC	PNP / NO PNP / NC NPN / NO NPN / NC
Connection type		2-polig	3-polig
Display LED yellow		yes (not Reed NC)	
Operating voltage Ub	V	10 - 30 AC/DC	10 - 30 DC
Ripple of Ub	%	≤ 10	≤ 10
Voltage drop	V	≤ 3	≤ 2
Current consumption unloaded Ub = 24V	mA	–	≤ 10
Permanent current	mA	≤ 500	≤ 200
Switching capacity	W	≤ 6	–
Switchable capacity @ 100 W @ 24 VDC	nF	100	–
Switching frequency	Hz	≤ 400	≤ 1.000
Switching time (On/Off)	ms	1.5 / 0,5	0.5 / 0.5
Switch-point accuracy	mm	≤ 0.2	≤ 0.2
Hysteresis	mm	2	2
EMC to EN 60947-5-2		yes	yes
Hysteresis		≥ 20 10 <sup>6</sup> cycles	unlimited
Short-circuit protection		–	yes
Reverse polarity protection		–	yes
Power-up pulse Suppression		–	yes
Protection for inductive load		–	yes
ATEX certification		–	on request
<b>Mechanical specifications</b>			
Housing			PA12
Connection cable		PUR, black	
Cable cross-section	mm <sup>2</sup>	2 x 0.14	3 x 0.14
Bending radius fixed installation	mm	≥ 30	
Bending radius moving	mm	≥ 45	
<b>Ambient conditions</b>			
Protection (EN 60529)	IP	68	
Ambient temperature range	°C	- 30 up to + 80	
Vibration EN 60068-2-6	G	30, 11 ms, 10 up to 55 Hz, 1 mm	
Shock EN 60068-2-27	G	50, 11 ms	



## Switching function and electrical connection

Reed 2-pole

**normally open**

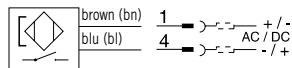

**normally closed**

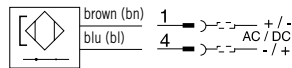

PNP 3-pole

**normally open**

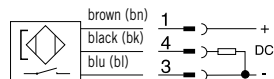

**normally closed**

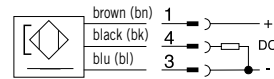

NPN 3-pole

**normally open**



**normally closed**

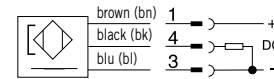

## Dimensions (mm) - Type P8S

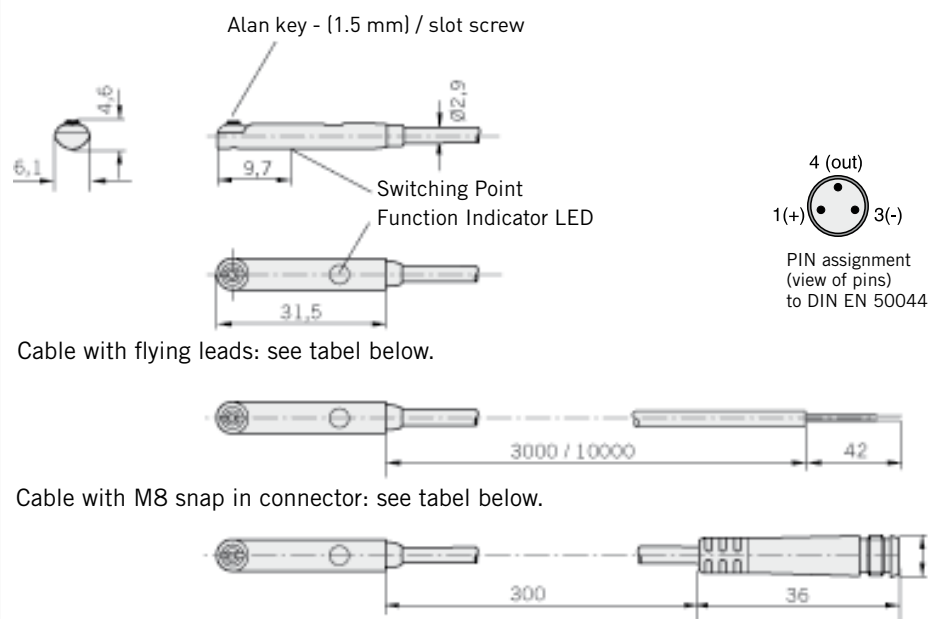

Cable with flying leads: see label below.

Cable with M8 snap in connector: see label below.

## Installation for Magnetic T-Slot Sensors

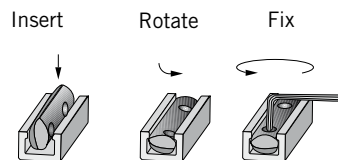

## Order Numbers

### Magnetic Sensors for all HMR Products

	M8 plug, snap in		FL = flying lead	
	0.3 m	3 m	3 m	10 m
Reed Normally Open (2-wire)	P8S-GRSHX	P8S-GRFAX	P8S-GRFDX	
Reed Normally Closed (2-wire)	P8S-GESNX	P8S-GEFFX	P8S-GEFRX	
PNP Normally Open	P8S-GPSHX	P8S-GPFAX	P8S-GPFDX	
PNP Normally Closed	P8S-GQSHX	P8S-GQFAX	P8S-GQFDX	
NPN Normally Open	P8S-GNSHX	P8S-GNFAX	P8S-GNFDX	
NPN Normally Closed	P8S-GMSHX	P8S-GMFAX	P8S-GMFDX	

### Connection Cables suitable for cable chain

M8 Plug with 5 m cable	KL3186		
M8 Plug with 10 m cable	KL3217		
M8 Plug with 15 m cable	KL3216		

# ORIGA Linear Drives

*HMR series*

*Option*

*Position detection*

**Magnetic switches  
RS and ES**

## Electric Service Life

### Protective Measures

Type RS magnetic sensors are sensitive to excessive currents and inductions. With high switching frequencies and inductive loads such as relays, solenoid valves or lifting magnets, service life will be greatly reduced.

With resistive and capacitive loads with high switch-on current, such as light bulbs, a protective resistor should be fitted. This also applies to long cable lengths and voltages over 100 V.

In the switching of inductive loads such as relays, solenoid valves and lifting magnets, voltage peaks (transients) are generated which must be suppressed by protective diodes, RC loops or varistors.

## Connection Examples

Load with protective circuits  
(a) Protective resistor for light bulb  
(b) Freewheel diode on inductivity  
(c) Varistor on inductivity  
(d) RC element on inductivity

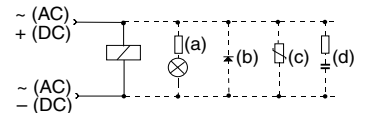

For the type ES, external protective circuits are not normally needed.





# HMR Accessories



# ORIGA Linear Drives

HMR series

Accessories

Coupling housing

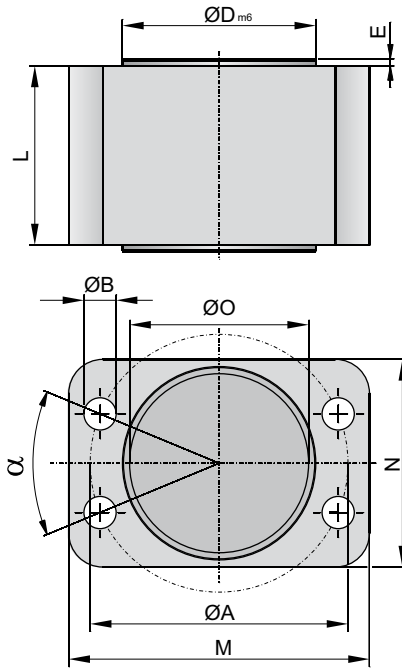

**Dimension table - Coupling housing long HMRS / HMRB**

Product size	$\text{Ø} A$	$\text{Ø} B$	$\text{Ø} D_{m6}$	E	$\text{Ø} O$	L	M	N	Order no.
HMRx15	72	9,0	54	2	50	54	84	58	50353FIL
HMRx18	80	9,0	64	2	60	70	90	68	50655FIL
HMRx24	95	11,0	80	2	77	85	107	85	56415FIL

- suitable for all types of HMR
- suitable for HMR with motor orientation 000° top (HMRBxxxAP; HMRBxxxAD)
- suitable for HMR with motor orientation 180° bottom and profile version Basic (HMRBxxBCP; HMRBxxBCD; HMRBxxCCP; HMRBxxCCD)

**Dimension table - Coupling housing short HMRB**

Product size	$\text{Ø} A$	$\text{Ø} B$	$\text{Ø} D_{m6}$	E	$\text{Ø} O$	L	M	N	Order no.
HMRB15	72	9,0	54	2	50	30	84	58	56412FIL
HMRB18	80	9,0	64	2	60	42	90	68	56413FIL
HMRB24	95	11,0	80	2	77	60	107	85	56414FIL

- suitable for HMR with motor orientation 090° front and 270° rear (HMRBxxxBD; HMRBxxxDD)
- suitable for HMR with motor orientation 180° bottom re-inforced profile (HMRBxxRCP; HMRBxxRCD; HMRBxxSCP; HMRBxxSCD)

Dimensions in mm



# ORIGA Linear Drives

*HMR series*

*Accessories*

*Motor coupling*

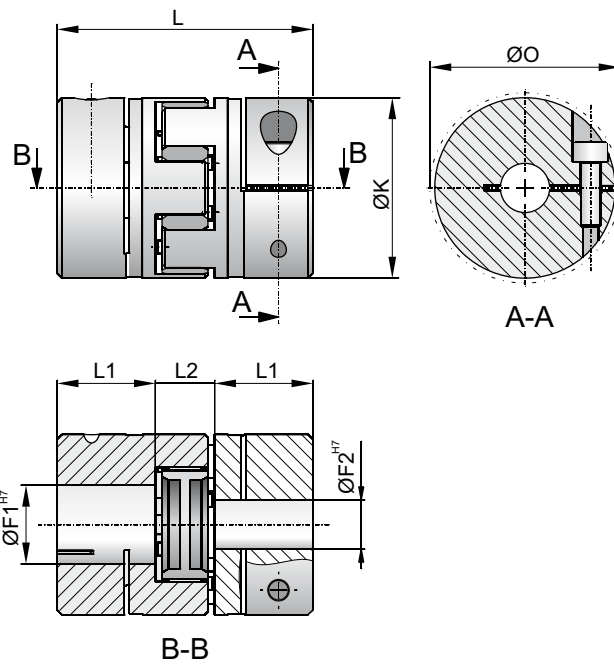

## Ball screw

**Dimension table - motor coupling HMRS**

Product size	F <sub>1</sub>	F <sub>2</sub>	F	K	L	L <sub>1</sub>	L <sub>2</sub>	Ø 0	Order no.
HMRS15	12	9	8 - 24	40	66	25	16	58	56400FIL
HMRS18	15	14	10 - 28	55	78	30	18	68	56402FIL
HMRS24	20	14	14 - 38	65	90	35	20	73	56510FIL

## Belt

**Dimension table - motor coupling HMRB**

Product size	F <sub>1</sub>	F <sub>2</sub>	F	K	L	L <sub>1</sub>	L <sub>2</sub>	Ø 0	Order no.
HMRB15	15	10	8 - 24	40	66	25	16	58	16239FIL
HMRB18	18	14	10 - 28	55	78	30	18	68	56411FIL
HMRB24	24	15	14 - 38	65	90	35	20	73	16260FIL

Dimensions in mm



# ORIGA Linear Drives

HMR series

Accessories

Mountings

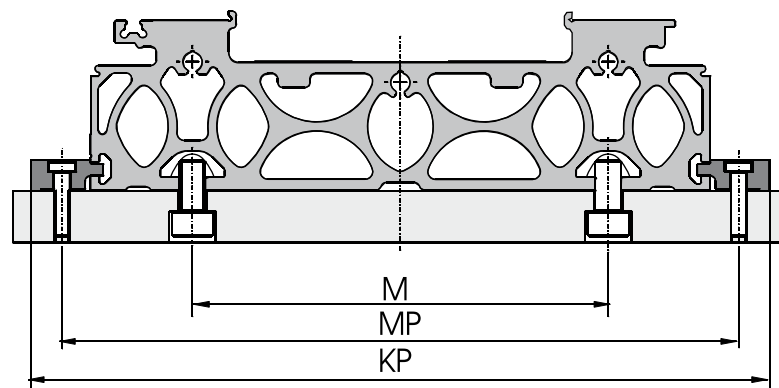

Dimension table - Product width HMR

Product size	T-slot fixture		T-slot mounting
	MP	KP	M
HMRx15	170	190	96
HMRx18	202	226	1160
HMRx24	262	286	161

Max. axial holding force per mounting set

Product size		T-slot fixture	T-slot mounting	min. number of sets required
HMRx15	N	1820	1600	2
HMRx18	N	2610	2700	2
HMRx24	N	2610	3200	3

Dimensions in mm

# ORIGA Linear Drives

*HMR series*

*Accessories*

*T-slot mounting*

*T-slot fixture*

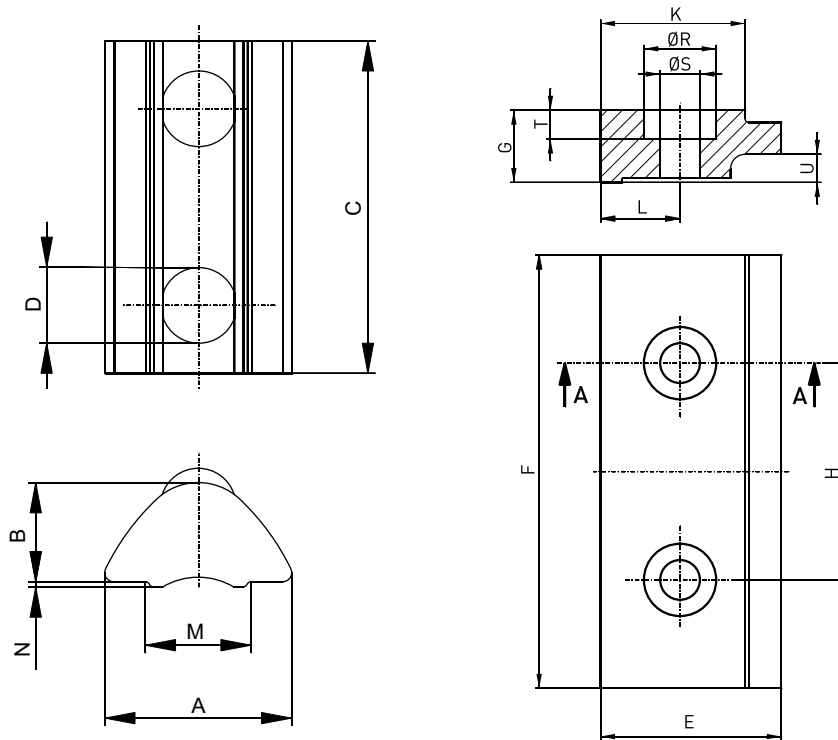

**Dimension table - T-slot mounting HMR**

Product size	A	B	C	Ø D	M	N	Order no. *
HMRx15	10.5	6.4	22.5	M6	6.4	0.6	56352FIL
HMRx18	13.5	6.7	22.5	M8	8.5	1.0	56353FIL
HMRx24	16.5	8.9	28.5	M10	10.5	1.0	56354FIL

\* Packing unit 10 pc



**Dimension table - T-slot fixture HMR**

Product size	E	F	G	H	K	L	Ø R	Ø S	T	U	Order no. *
HMRx15	25	60	10	30	20	11	10	5.5	4.0	3.9	56355FIL
HMRx18	28	80	12	40	23	12	11	6.6	4.7	5.9	56356FIL
HMRx24	28	80	12	40	23	12	11	6.6	4.7	5.9	56356FIL

\* Packing unit 1 pair incl. screws



Dimensions in mm

# Parker Worldwide

## Europe, Middle East, Africa

**AE – United Arab Emirates,**  
Dubai

Tel: +971 4 8127100  
parker.me@parker.com

**AT – Austria,** Wiener Neustadt

Tel: +43 (0)2622 23501-0  
parker.austria@parker.com

**AT – Eastern Europe,** Wiener  
Neustadt

Tel: +43 (0)2622 23501 900  
parker.easteurope@parker.com

**AZ – Azerbaijan,** Baku

Tel: +994 50 2233 458  
parker.azerbaijan@parker.com

**BE/LU – Belgium,** Nivelles

Tel: +32 (0)67 280 900  
parker.belgium@parker.com

**BY – Belarus,** Minsk

Tel: +375 17 209 9399  
parker.belarus@parker.com

**CH – Switzerland,** Etoy

Tel: +41 (0)21 821 87 00  
parker.switzerland@parker.com

**CZ – Czech Republic,** Klecany

Tel: +420 284 083 111  
parker.czechrepublic@parker.com

**DE – Germany,** Kaarst

Tel: +49 (0)2131 4016 0  
parker.germany@parker.com

**DK – Denmark,** Ballrup

Tel: +45 43 56 04 00  
parker.denmark@parker.com

**ES – Spain,** Madrid

Tel: +34 902 330 001  
parker.spain@parker.com

**FI – Finland,** Vantaa

Tel: +358 (0)20 753 2500  
parker.finland@parker.com

**FR – France,** Contamine s/Arve

Tel: +33 (0)4 50 25 80 25  
parker.france@parker.com

**GR – Greece,** Athens

Tel: +30 210 933 6450  
parker.greece@parker.com

**HU – Hungary,** Budapest

Tel: +36 1 220 4155  
parker.hungary@parker.com

**IE – Ireland,** Dublin

Tel: +353 (0)1 466 6370  
parker.ireland@parker.com

**IT – Italy,** Corsico (MI)

Tel: +39 02 45 19 21  
parker.italy@parker.com

**KZ – Kazakhstan,** Almaty

Tel: +7 7272 505 800  
parker.easteurope@parker.com

**NL – The Netherlands,** Oldenzaal

Tel: +31 (0)541 585 000  
parker.nl@parker.com

**NO – Norway,** Asker

Tel: +47 66 75 34 00  
parker.norway@parker.com

**PL – Poland,** Warsaw

Tel: +48 (0)22 573 24 00  
parker.poland@parker.com

**PT – Portugal,** Leca da Palmeira

Tel: +351 22 999 7360  
parker.portugal@parker.com

**RO – Romania,** Bucharest

Tel: +40 21 252 1382  
parker.romania@parker.com

**RU – Russia,** Moscow

Tel: +7 495 645-2156  
parker.russia@parker.com

**SE – Sweden,** Spånga

Tel: +46 (0)8 59 79 50 00  
parker.sweden@parker.com

**SK – Slovakia,** Banská Bystrica

Tel: +421 484 162 252  
parker.slovakia@parker.com

**SL – Slovenia,** Novo Mesto

Tel: +386 7 337 6650  
parker.slovenia@parker.com

**TR – Turkey,** Istanbul

Tel: +90 216 4997081  
parker.turkey@parker.com

**UA – Ukraine,** Kiev

Tel: +380 44 494 2731  
parker.ukraine@parker.com

**UK – United Kingdom,** Warwick

Tel: +44 (0)1926 317 878  
parker.uk@parker.com

**ZA – South Africa,** Kempton Park

Tel: +27 (0)11 961 0700  
parker.southafrica@parker.com

## North America

**CA – Canada,** Milton, Ontario

Tel: +1 905 693 3000

**US – USA,** Cleveland

Tel: +1 216 896 3000

## Asia Pacific

**AU – Australia,** Castle Hill

Tel: +61 (0)2-9634 7777

**CN – China,** Shanghai

Tel: +86 21 2899 5000

**HK – Hong Kong**

Tel: +852 2428 8008

**IN – India,** Mumbai

Tel: +91 22 6513 7081-85

**JP – Japan,** Tokyo

Tel: +81 (0)3 6408 3901

**KR – South Korea,** Seoul

Tel: +82 2 559 0400

**MY – Malaysia,** Shah Alam

Tel: +60 3 7849 0800

**NZ – New Zealand,** Mt Wellington

Tel: +64 9 574 1744

**SG – Singapore**

Tel: +65 6887 6300

**TH – Thailand,** Bangkok

Tel: +662 186 7000-99

**TW – Taiwan,** Taipei

Tel: +886 2 2298 8987

## South America

**AR – Argentina,** Buenos Aires

Tel: +54 3327 44 4129

**BR – Brazil,** Sao Jose dos Campos

Tel: +55 800 727 5374

**CL – Chile,** Santiago

Tel: +56 2 623 1216

**MX – Mexico,** Apodaca

Tel: +52 81 8156 6000

### Parker Hannifin GmbH

Pat-Parker-Platz 1  
41564 Kaarst (Germany)

Tel.: + 49 (0)2131 4016-0

Fax: + 49 (0)2131 4016-9199

Internet: [www.parker.com](http://www.parker.com)

E-Mail: [parker.germany@parker.com](mailto:parker.germany@parker.com)

